

ATV610 Multi-pump Introduction

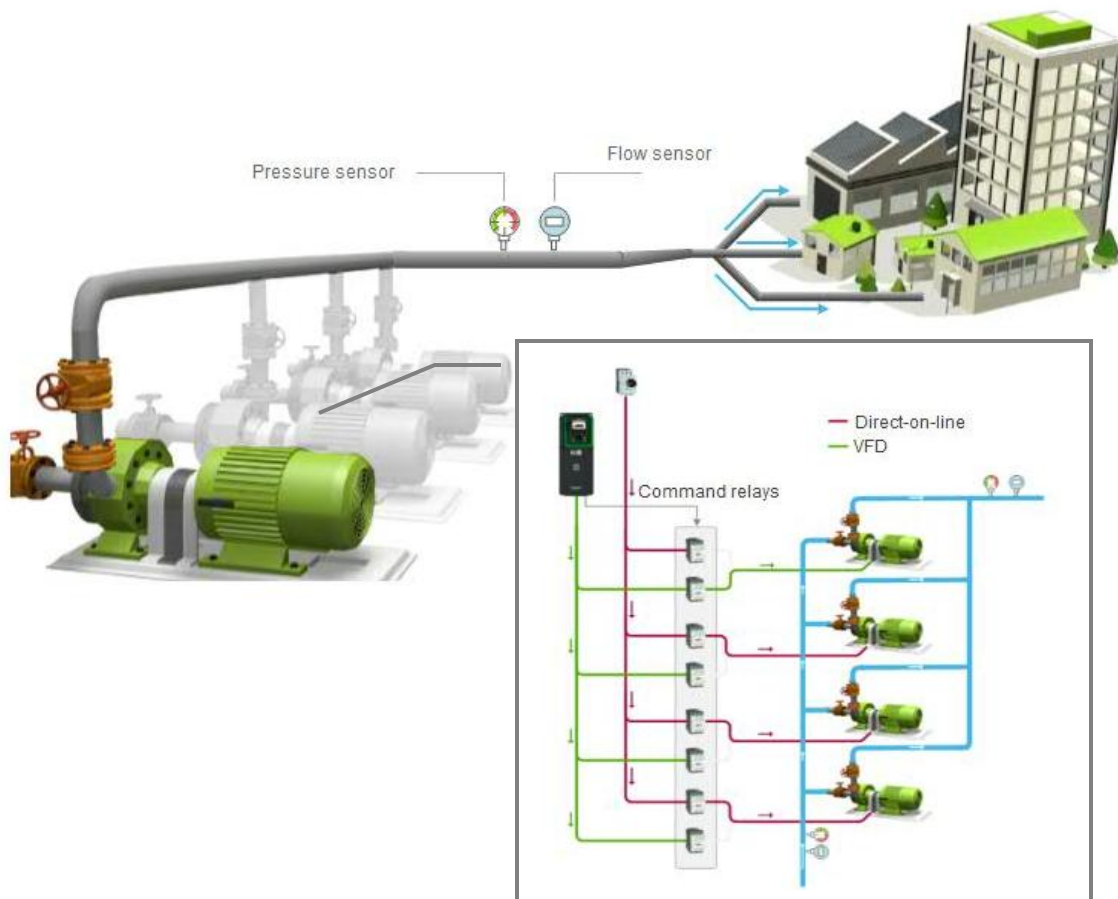

Four Multi-pump application scenarios

The objective of this function is to manage the starting and stopping of pumps (variable speed pumps and fixed speed pumps) in multi-pump system according to demand coming from Application Control (e.g. Booster Control, Level Control ...). Now in the market, there are 4 kinds of solutions usually seen.

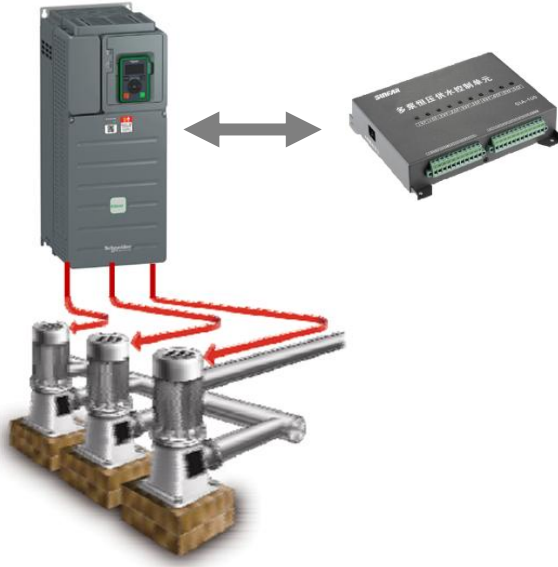

VSD + Dedicated controller

The function of this controller is like PLC, already with dedicated multi-pump program embedded. Very less customers (<5%) may use this solution.

Advantage: No additional programming workload; Easy maintenance for end-users.

Disadvantage: Not compatible with other system.

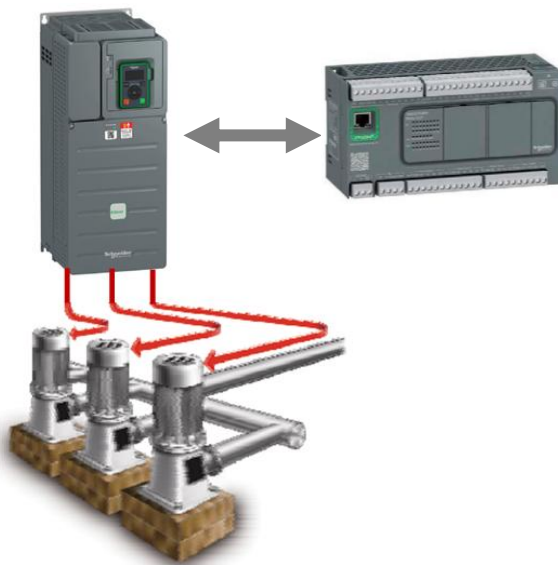

VSD + PLC

It's the most common seen in this market. More than 60% customers adopt this kind of solution. Multi-pump function shall be programmed in each PLC.

Advantage: Compatible with other system; Easy integrated with automation system; Easy maintenance for end-users.

Disadvantage: Higher cost



VSD embedded with Multi-pump function

20-30% customers pick this solution, which is **typical application of ATV610**. No additional PLC is needed.

Advantage: Lower cost; Easy installation

Disadvantage: More complicated maintenance because of multi-pump configuration on VSD.

Strongly suggest end-user keeping a keypad which saved full configuration.



Multi VSD + Multi pump

This advanced solution accounts 5%-10% which is usually promoted for KA customers. Each pump is driven by one VSD. All drives are working as Master-slave function to balance load.

Advantage: Most energy saving; Redundancy system; Increase pump lifetime.

Disadvantage: Very high cost

ATV610 Multi-pump function: architecture and parameter setting

Multi-Pump1: Basic "1VSD-NDOL" Architecture

One Variable Speed Pump is controlled by VSD and N auxiliary Fixed Speed Pump controlled by DOL using simple relays. Comparing the outlet pressure feedback with the water demand, drive controls the relays to start or stop the auxiliary pump.

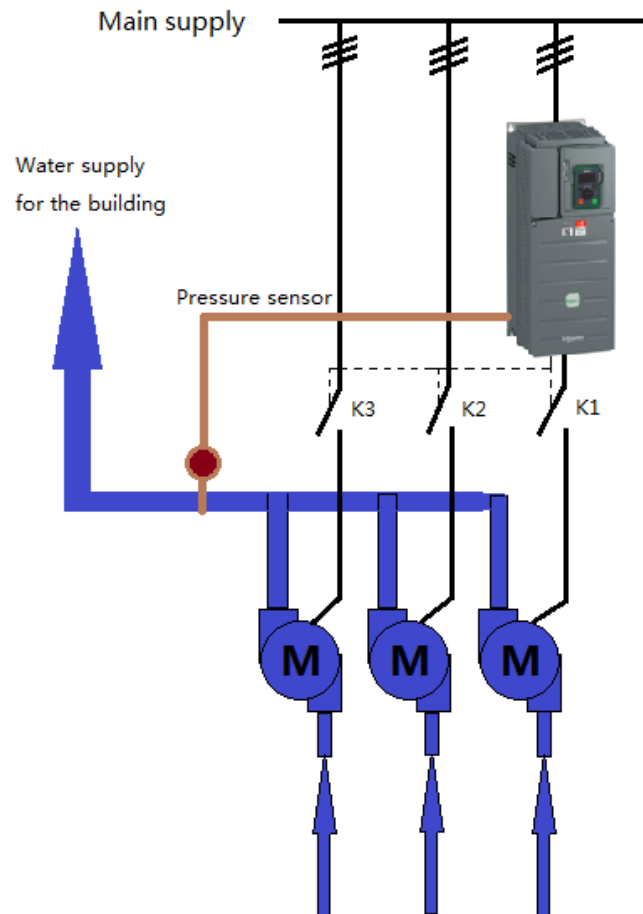

Multi-Pump2: "1VSD-NDOL" with Lead Pump Alternation

Each pump can be connected to VSD and others become auxiliary pumps connected DOL. Lead pump alternation during staging and de-staging ensures soft starter for each pump and balance the operation time among all pumps.

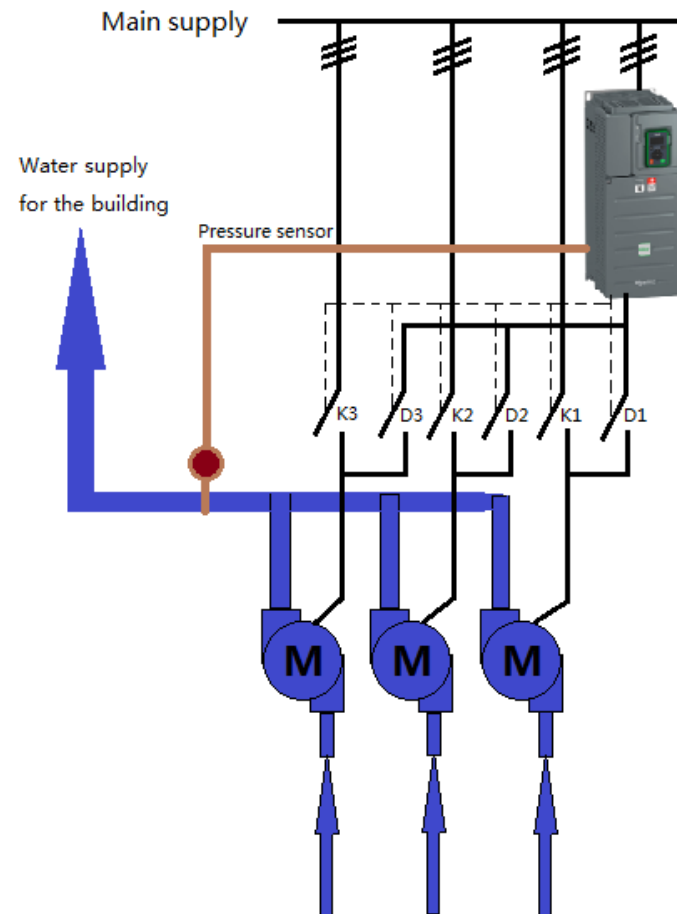

[Multi-pump1] bMP1

Pump 2 and pump 3 are controlled by relay outputs R2 and R3. The state of each pump is provided to the drive via digital inputs DI2 and DI3:
 1 = the pump is ready to operate; 0 = the pump is not available.
 KM1 is switched ON when CP1 is activated. CP1 is controlled via the relay output R2.
 KM2 is switched ON when CP2 is activated. CP2 is controlled via the relay output R3.
 Q1 and Q2 must be switched ON to have both pump 2 and pump 3 ready to operate.

Wiring example:

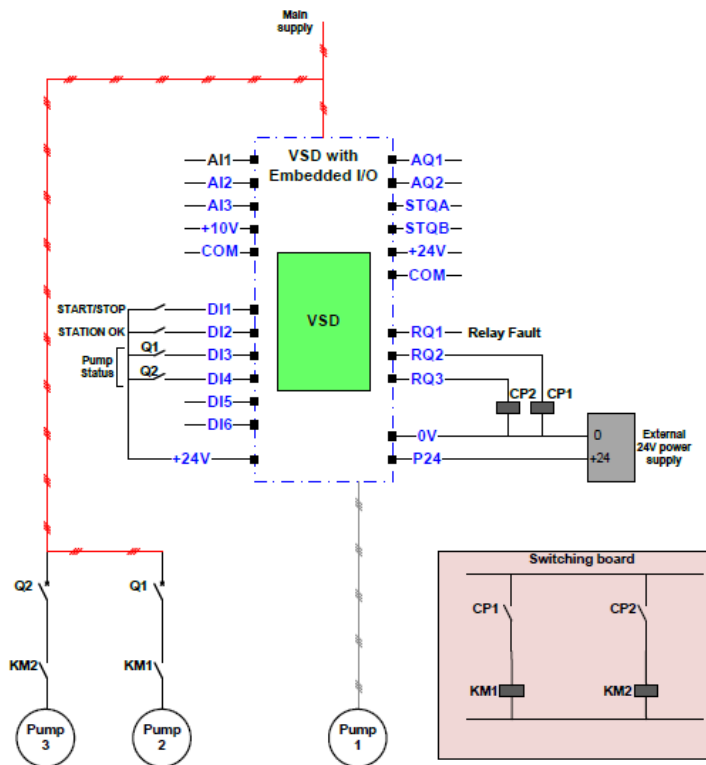

Macro [Multi-Pump1] I/O default setting

I/O	[Multi-Pump 1]bmp1
DI1	[Start/ Stop]
DI2	Not assigned
DI3	Not assigned
DI4	Not assigned
DI5	Not assigned
DI6	Not assigned
AI1	[Ref Freq 1 Config]
AI2	[PID feedback]
AQ1	[Motor frequency]4-20mA
AQ2	[Motor current]4-20mA
R1	[Operating state fault]
R2	[Pump2 Cmd]
R3	[Pump3 Cmd]

[Multi-pump 1] Marco configuration typical parameter setting			
Parameter	Path	Default	Comments
R1 CONFIGURATION	[Complete setting] [Input/ Output] [R1 configuration]	FLT	Refer to programming manual
R2 CONFIGURATION	[Complete setting] [Input/ Output] [R2 configuration]	pump2	Refer to programming manual
R3 CONFIGURATION	[Complete setting] [Input/ Output] [R3 configuration]	pump3	Refer to programming manual
AO1 assignment	[Complete setting] [Input/ Output] [AQ1 configuration]	Motor freq.	If assigned to Motor frequency, its corresponding range is from LSP-TFR. And TFR default is 60Hz. So it should be modified in each case.
AO1 Type	[Complete setting] [Input/ Output] [AQ1 configuration]	current	Current or Voltage
AO1 min output	[Complete setting] [Input/ Output] [AQ1 configuration]	4mA	0~20mA / 0~10V
AO1 max output	[Complete setting] [Input/ Output] [AQ1 configuration]	20mA	0~20mA / 0~10V
AO2 assignment	[Complete setting] [Input/ Output] [AQ2 configuration]	Motor current	Refer to programming manual
AO2 Type	[Complete setting] [Input/ Output] [AQ2 configuration]	current	Current or Voltage
AO2 min output	[Complete setting] [Input/ Output] [AQ2 configuration]	4mA	0~20mA / 0~10V
AO2 max output	[Complete setting] [Input/ Output] [AQ1 configuration]	20mA	0~20mA / 0~10V
AI1 type	[Complete setting] [Input/ Output] [AI1 configuration]	voltage	Current or Voltage
AI1 min value	[Complete setting] [Input/ Output] [AI1 configuration]	0V	0~20mA / 0~10V
AI1 max value	[Complete setting] [Input/ Output] [AI1 configuration]	10V	0~20mA / 0~10V
AI2 type	[Complete setting] [Input/ Output] [AI2 configuration]	current	Current or Voltage
AI2 min value	[Complete setting] [Input/ Output] [AI2 configuration]	4mA	0~20mA / 0~10V
AI2 max value	[Complete setting] [Input/ Output] [AI2 configuration]	20mA	0~20mA / 0~10V
Profile(CHCF)	[Complete setting] [Command and Reference]	SIM	Control mode can be [Not separ.], [Separate], [I/O profile], where command signal and frequency signal are through same mode or separated mode.
Cmd switching	[Complete setting] [Command and Reference]	CD1	Assign a DI terminal to switch command channel, DI=0: Command channel is CD1, DI=1, Command channel is CD2
Cmd channel 1	[Complete setting] [Command and Reference]	Terminals	Can assign to Terminal, or HMI, or Modbus, or Fieldbus
Cmd channel 2	[Complete setting] [Command and Reference]	Modbus	Can assign to Terminal, or HMI, or Modbus, or Fieldbus
Ref. 2 switching(rfc)	[Complete setting] [Command and Reference]	Fr1	Assign a DI terminal to switch command channel, DI=0, Frequency channel is Fr1; DI=1, Frequency channel is Fr2
Ref.1 channel	[Complete setting] [Command and Reference]	AI1	Assign to AI1-AI6, Display terminal, Modbus, other fieldbus module, or DI5-DI6 as pulse input
Ref.2 channel	[Complete setting] [Command and Reference]	No	Switching frequency channel can also realize +/- speed function

2/3 wire control	[Complete setting] [Input/ Output] [Input/ Output]	2C	Can choose 2 wire control or 3 wire control. 2 wire control is default setting
Reverse assign.	[Complete setting] [Input/ Output] [Input/ Output]	No	Set DI terminal to proceed motor reverse
FAULT RESET	[Complete setting] [Error/Warning handling] [Fault reset]	DI2	DI2 is Fault Reset in this Marco default setting
[PID feedback ass.] (PIF)	[Complete setting] [Generic functions] [PID controller] [Feedback]	AI2	PID function is activated after PID feedback is assigned.
2 preset speeds (PS2)	[Complete setting] [Generic functions] [Preset speeds]	No	If 2 preset speeds are needed, assign 1 DI terminal.
4 preset speeds (PS4)	[Complete setting] [Generic functions] [Preset speeds]	No	If 4 preset speeds are needed, assign 2 DI terminals
PRESET SPEEDS 2	[Complete setting] [Generic functions] [Preset speeds]	10	
PRESET SPEEDS 3	[Complete setting] [Generic functions] [Preset speeds]	20	
PRESET SPEEDS 4	[Complete setting] [Generic functions] [Preset speeds]	30	
LSP (Low speed)	[Complete setting] [Command and Reference]	10Hz	
MPSA (Multi-Pump System Architecture)	[Complete setting] [Pump functions] [Booster control] [System]	1VSDNDOL	
BCM (Booster Control Mode)	[Complete setting] [Pump functions] [Booster control] [Booster control]	YES	
MPPN (Multi-Pump System' s Pump Number)	[Complete setting] [Pump functions] [Booster control] [System]	3	Maximum 6 pumps (with extension relay module)
MPPC (Multi-Pump Pump Cycling)	[Complete setting] [Pump functions] [Booster control] [System]	RTIME	Define the pump cycling first in first out or Last in first out
MPLA (Multi-Pump Lead Alternation)	[Complete setting] [Pump functions] [Booster control] [System]	NO	Under this case, the lead pump is fixed
MPID (Multi-Pump Interlock Delay)	[Complete setting] [Pump functions] [Booster control] [System]	0	
MPFB (Multi-Pump Fault Behavior)	[Complete setting] [Pump functions] [Booster control] [System]	Yes	Once there is fault, VSD stop operation, the motor freewheel stop.
TOCT (Type of control PID)	[Complete setting] [Generic functions] [PID controller] [Feedback]	PRESS	Type of control can be set as Pressure, Flow or others.
RPG	[Complete setting] [Generic functions] [PID controller] [Settings]	50	PID proportion parameter: setting range 0.01-100. Increase Proportion parameter if the system reacts too slowly; decrease this parameter if it appears overshoot.
RIG	[Complete setting] [Generic functions] [PID controller] [Settings]	100	PID integration parameter: setting range 0.01-100. If there is big error, increase this parameter; decrease if system reacts too slowly.

[Multi-Pump 2] bmp2

With this architecture, Pump 1, 2 and 3 control via relay output R2, R3 and R4. The state of each pump is provided to the drive via digital inputs DI2, DI3, and DI4: 1 = the pump is ready to operate. 0 = the pump is not available. If the relay output R2 is the first activated, the pump 1 becomes the lead pump. CP1 is switched ON via relay output R2, KD1 is switched ON and the pump 1 is connected to the drive. The other pumps cannot be connected to the drive thanks to KD1 (switched OFF). The other pumps become auxiliary pumps and they are connected to the supply mains through KM2 and KM3 which are activated when, respectively, CP2 and CP3 are switched ON, that is, when R3 and R4 are activated.

Q1, Q2, and Q3 must be switched ON to have all pumps ready to operate. During staging and de-staging, the lead pump could be changed to the other immediately; the alternation order could be set by parameter MPPC in the drive.

Wiring example

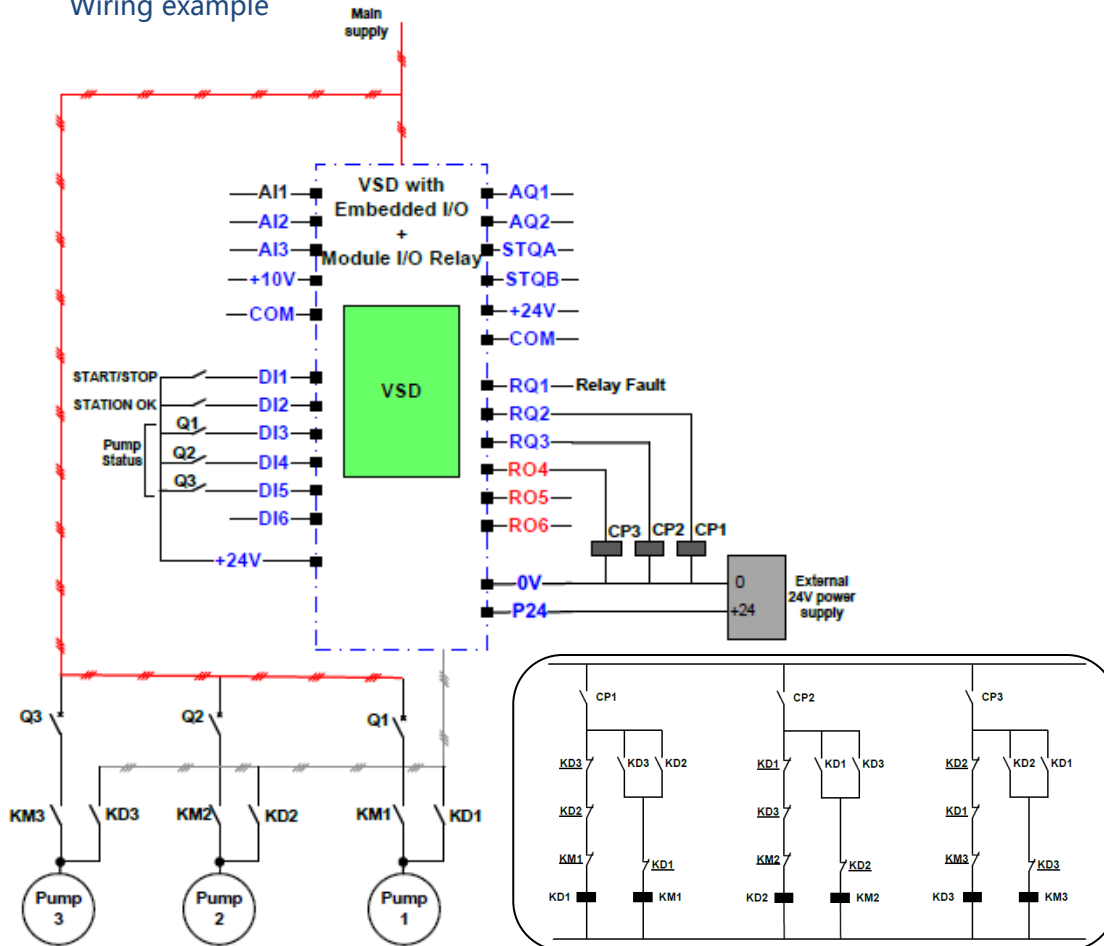

Macro [Multi-Pump2] I/O default setting

I/O	[Multi-Pump 2]bmp2
DI1	[Start/ Stop]
DI2	Not assigned
DI3	Not assigned
DI4	Not assigned
DI5	Not assigned
DI6	Not assigned
AI1	[Ref Freq 1 Config]
AI2	[PID feedback]
AQ1	[Motor frequency]4-20mA
AQ2	[Motor current]4-20mA
R1	[Operating state fault]
R2	[Pump1 Cmd]
R3	[Pump2 Cmd]

[Multi-pump 2] Marco configuration typical parameter setting			
Parameter	Path	Default	Comments
R1 CONFIGURATION	[Complete setting] [Input/ Output] [R1 configuration]	FLT	Refer to programming manual
R2 CONFIGURATION	[Complete setting] [Input/ Output] [R2 configuration]	Pump1	Refer to programming manual
R3 CONFIGURATION	[Complete setting] [Input/ Output] [R3 configuration]	Pump2	Refer to programming manual
AO1 assignment	[Complete setting] [Input/ Output] [AQ1 configuration]	Motor freq.	If assigned to Motor frequency, its corresponding range is from LSP-TFR. And TFR default is 60Hz. So it should be modified in each case.
AO1 Type	[Complete setting] [Input/ Output] [AQ1 configuration]	current	Current or Voltage
AO1 min output	[Complete setting] [Input/ Output] [AQ1 configuration]	4mA	0~20mA / 0~10V
AO1 max output	[Complete setting] [Input/ Output] [AQ1 configuration]	20mA	0~20mA / 0~10V
AO2 assignment	[Complete setting] [Input/ Output] [AQ2 configuration]	Motor current	Refer to programming manual
AO2 Type	[Complete setting] [Input/ Output] [AQ2 configuration]	current	Current or Voltage
AO2 min output	[Complete setting] [Input/ Output] [AQ2 configuration]	4mA	0~20mA / 0~10V
AO2 max output	[Complete setting] [Input/ Output] [AQ1 configuration]	20mA	0~20mA / 0~10V
AI1 type	[Complete setting] [Input/ Output] [AI1 configuration]	voltage	Current or Voltage
AI1 min value	[Complete setting] [Input/ Output] [AI1 configuration]	0V	0~20mA / 0~10V
AI1 max value	[Complete setting] [Input/ Output] [AI1 configuration]	10V	0~20mA / 0~10V
AI2 type	[Complete setting] [Input/ Output] [AI2 configuration]	current	Current or Voltage
AI2 min value	[Complete setting] [Input/ Output] [AI2 configuration]	4mA	0~20mA / 0~10V
AI2 max value	[Complete setting] [Input/ Output] [AI2 configuration]	20mA	0~20mA / 0~10V
Profile(CHCF)	[Complete setting] [Command and Reference]	SIM	Control mode can be [Not separ.], [Separate], [I/O profile], where command signal and frequency signal are through same mode or separated mode.
Cmd switching	[Complete setting] [Command and Reference]	CD1	Assign a DI terminal to switch command channel, DI=0: Command channel is CD1, DI=1, Command channel is CD2
Cmd channel 1	[Complete setting] [Command and Reference]	Terminals	Can assign to Terminal, or HMI, or Modbus, or Fieldbus
Cmd channel 2	[Complete setting] [Command and Reference]	Modbus	Can assign to Terminal, or HMI, or Modbus, or Fieldbus
Ref. 2 switching(rfc)	[Complete setting] [Command and Reference]	Fr1	Assign a DI terminal to switch command channel, DI=0, Frequency channel is Fr1; DI=1, Frequency channel is Fr2
Ref.1 channel	[Complete setting] [Command and Reference]	AI1	Assign to AI1-AI6, Display terminal, Modbus, other fieldbus module, or DI5-DI6 as pulse input
Ref.2 channel	[Complete setting] [Command and Reference]	No	Switching frequency channel can also realize +/- speed function
2/3 wire control	[Complete setting] [Input/ Output] [Input/ Output]	2C	Can choose 2 wire control or 3 wire control. 2 wire control is default setting

Reverse assign.	[Complete setting] [Input/ Output] [Input/ Output]	No	Set DI terminal to proceed motor reverse
FAULT RESET	[Complete setting] [Error/Warning handling] [Fault reset]	DI2	DI2 is Fault Reset in this Marco default setting
[PID feedback ass.] (PIF)	[Complete setting] [Generic functions] [PID controller] [Feedback]	AI2	PID function is activated after PID feedback is assigned.
2 preset speeds (PS2)	[Complete setting] [Generic functions] [Preset speeds]	No	If 2 preset speeds are needed, assign 1 DI terminal.
4 preset speeds (PS4)	[Complete setting] [Generic functions] [Preset speeds]	No	If 4 preset speeds are needed, assign 2 DI terminals
PRESET SPEEDS 2	[Complete setting] [Generic functions] [Preset speeds]	10	
PRESET SPEEDS 3	[Complete setting] [Generic functions] [Preset speeds]	20	
PRESET SPEEDS 4	[Complete setting] [Generic functions] [Preset speeds]	30	
LSP (Low speed)	[Complete setting] [Command and Reference]	10Hz	
MPSA (Multi-Pump System Architecture)	[Complete setting] [Pump functions] [Booster control] [System]	1VSDNDOL	
BCM (Booster Control Mode)	[Complete setting] [Pump functions] [Booster control] [Booster control]	YES	
MPPN (Multi-Pump System' s Pump Number)	[Complete setting] [Pump functions] [Booster control] [System]	3	Maximum 6 pumps (with extension relay module)
MPPC (Multi-Pump Pump Cycling)	[Complete setting] [Pump functions] [Booster control] [System]	RTIME	Define the pump cycling first in first out or Last in first out
MPLA (Multi-Pump Lead Alternation)	[Complete setting] [Pump functions] [Booster control] [System]	STAGE	Lead pump alternation
MPID (Multi-Pump Interlock Delay)	[Complete setting] [Pump functions] [Booster control] [System]	0	
MPFB (Multi-Pump Fault Behavior)	[Complete setting] [Pump functions] [Booster control] [System]	Yes	Once there is fault, VSD stop operation, the motor freewheel stop.
TOCT (Type of control PID)	[Complete setting] [Generic functions] [PID controller] [Feedback]	PRESS	Type of control can be set as Pressure, Flow or others.
RPG	[Complete setting] [Generic functions] [PID controller] [Settings]	50	PID proportion parameter: setting range 0.01-100. Increase Proportion parameter if the system reacts too slowly; decrease this parameter if it appears overshoot.
RIG	[Complete setting] [Generic functions] [PID controller] [Settings]	100	PID integration parameter: setting range 0.01-100. If there is big error, increase this parameter; decrease if system reacts too slowly.